

# Cambs & Hunts Bridge

Number 65, October 2013

## Cambs & Hunts news

We are sad to report the death of Nicholas Bull, a long-standing member of several C&H clubs. He will be much missed for his wonderful sense of humour, not to mention his marvellous marmalade and other charitable activities. Our best wishes go to Cynthia and her family.

Jonathan Mestel, Julian Wightwick, Paul Barden, Cath and Chris Jagger retained the Pachabo Inter-County Teams Trophy for Cambs & Hunts. Marion & Trevor King, Chris & Christine Heames won the 2012/13 County Plate competition. Cambridge E (Peter Bhagat, John Liebeschuetz, Mike Seaver & Clive Stops) lost the final of the NICKO Plate to West of England C. Graham Dolan, David Carmichael, Roger Courtney & Robin Cambery won the Essex/Herts One-Day Swiss Teams in July.

### County Teams KO is now free!

Green-pointed teams-of-four knockout.  
Plate event for first-round losers.

Entries to Chris Jagger.  
chjagger@deloitte.co.uk,  
Tel: 01223 321910

14 St Barnabas Court, CB1 2BZ.

**Closing date Monday 14th October**

### C&H Open Swiss Teams

The County's prestige teams-of-four  
one-day Swiss competition.  
Featuring Blue Points at no extra cost!

More details and entry form on p16.  
Entries to David Man, Tel: 01223  
660312, davidman22@talktalk.net

**Sunday 27th October, Trumpington**

## In this issue...

John Liebeschuetz dares us to dabble with **bridge online**, Paul Barden tells us tales of triumph in the **Pachabo**, Chris Jagger reviews **point-a-board scoring**, soon to be used in its first EBU event, and **Aunt Agony** changes her spots. There is the usual round-up of results from competitions, and news from the clubs – plus don't miss the **County Calendar** on p14 and the **Open Swiss Teams entry form** on p15.

### County website redesign

The website is about to be redesigned  
– and we'd welcome your views.

- *What three features did you value from the old website?*
- *What one new thing would you like to see?*

Please send your thoughts to [website-interest-group@cambsbridge.org.uk](mailto:website-interest-group@cambsbridge.org.uk)

Meanwhile the old website is still online at [www.cambsbridge.org.uk](http://www.cambsbridge.org.uk)

The next newsletter will be published in January. Please send in news, letters and hands no later than 15<sup>th</sup> December.

All contributions welcome!

Editors:

**Chris & Catherine Jagger**  
14 St Barnabas Court, St Barnabas Rd  
Cambridge, CB1 2BZ

Tel: 01223 321910

Email: [chjagger@deloitte.co.uk](mailto:chjagger@deloitte.co.uk)  
or [catherine@circaworld.com](mailto:catherine@circaworld.com)

## The Wicked Witch

by John Liebeschuetz

A play problem at teams:

♠ J10 ♥ K63 ♦ K7643 ♣ A106	N W   E S	♠ AQ5432 ♥ AQJ9 ♦ 2 ♣ 72
-------------------------------------	-----------------	-----------------------------------

You are in 4♠ by South on the lead of ♦J. There has been no opposition bidding, and it is IMP scoring. It doesn't look likely the lead is away from the ace so you duck in dummy and the jack holds the trick. The ♦10 follows and you ruff in hand. How do you play?

And the answer ...

Go careful for here be witches!

Bridge-base Online is truly wonderful and free (<http://www.bridgebase.com>). For no fee at all you can while away time on as many or as few hands as you like in the company of people in far-flung corners of the globe. No need to move from your house or even (as was the case for me a while back) your sick bed. And if you don't want to play you can always watch the masters performing miracles on Vu-Graph (or alternatively showing that they can err with the rest of us, giving us lesser mortals hope).

Try it I urge you. But before you do, a word of Warning. Beware of witches and warlocks and creatures of the underworld. The semi-anonymous environment of the internet makes it easy for the thin disguise of civilization to fracture and reveal what lies beneath.

For instance see what terrible thing happened to me here. My partner, a self proclaimed expert, was 'Host' of the table. She therefore could dictate who could sit at the table and had 'Power of Banishment' over those that might displease her. We had played several uneventful hands at IMPs and were a small number up when this play problem in 4♠ came along (I was South, the declarer).

♠ J10 ♥ K63 ♦ K7643 ♣ A106	N W   E S	♠ K87 ♥ 54 ♦ AQ985 ♣ K93
♠ 96 ♥ 10872 ♦ J10 ♣ QJ854		♠ AQ5432 ♥ AQJ9 ♦ 2 ♣ 72

J♦ was led and ducked all round followed by ♦10 again ducked all round and ruffed low in hand. Playing pairs you must try for the maximum and it is natural to cross to dummy and finesse in spades, making 11 tricks at least if the finesse wins.

Playing teams however you need to make sure of the contract. Suppose West has something like ♠Kxxx ♥xx ♦J10 ♣xxxxx, a perfectly reasonable hand. See what happens if you try a heart to the king and then take a losing spade finesse. A heart comes back and now you are stumped. You cross to dummy in trumps but have no safe way back to hand to draw the rest of the trumps. You might try ♣A and another but East wins and fires through a diamond promoting a second trump trick for West.

It is no better if you first cross to dummy with a club. Then West on winning the spade finesse, can put East in with a club to lead a diamond through.

The communication problems put the contract in danger if you try for the spade finesse. So I decided to simply lead a spade to the jack. This was won by East with the king and the ♠9 was returned. I discarded my losing club, making ten tricks. At this moment the wicked witch waved her wand ...

... and I found myself banished to the Nether Regions with a message in burning fire in front of me telling me "The Host has disconnected you from the Table".

Naturally I was not a little annoyed and sent the wicked witch a script asking what the reason for my banishment was. Very politely, of course, as it

might all have been an unfortunate magical mistake, and it doesn't do to upset witches without good reason.

However the reply I got put me in no doubt that the witch had taken great exception to my declarer play. She pointed out that everybody else had made 11 or 12 tricks, and a novice magician such as myself should really go and study the game more ...

So the internet bridge world is a wild and wonderful land. Do explore it but go with a book of proven counter-spells and substantial protective armour (i.e. a thick skin!).

**Earn Masterpoints online**

From 9 October the EBU will be running 16-board online duplicates on BBO on Wednesdays and Sundays at 4pm and midnight for \$1 per player.

**Pachabo 2013 by Paul Barden**

In June, the champion team from each county is invited to the Pachabo, a round-robin teams event, and in the past decade the team of Chris & Cath Jagger, Jonathan Mestel and Julian Wightwick has represented C&H a remarkable eight times. Last year the arrival of young Timothy obliged Cath to stay at home, so Jon Cooke was drafted in from the losing finalists, and the Pachabo Cup duly carried home in triumph to be laid at her feet. This year it's difficult for Chris and Cath to play together, whereas I've emerged from bridge semi-retirement in favour of work semi-retirement, so I was drafted in and the elder Jagers shared the county KO matches. For the Pachabo, it was Chris's turn to stay at home, so Cath, Jonathan, Julian and I rode forth to Daventry, bearing the trophy in a plastic bag.

The scoring is an unusual mix of point-a-board and aggregate. This encourages aggressive bidding and makes every trick count in the play. The computer dealt us a selection of interesting hands, setting up a tough but enjoyable event.

Three problems:

1) Play. RHO opens a weak 2♥ and you arrive in 4♠ on these cards:

EW Vul	♠ AQ6			
Dealer E	♥ AQ8			
	♦ QJ8765			
	♣ 8			
	<table border="1"> <tr><td>N</td></tr> <tr><td>W E</td></tr> <tr><td>S</td></tr> </table>	N	W E	S
N				
W E				
S				
	♠ KJ982			
	♥ J3			
	♦ K4			
	♣ K952			

LHO leads ♥4. RHO wins with the king and returns the ten, LHO playing the two. If you ask, you'll be told that the ten suggests preference for diamonds over clubs.

Plan the play.

2) Bidding.

You hold ♠QJ2 ♥J6 ♦AQ8732 ♣A4 at game all. LHO opens 3♠, which is passed round to you.

- a) What call do you make?
- b) If you bid 3NT, it goes pass, pass, double. What now?

3) Defence.

You hold ♠9875432 ♥1076 ♦103 ♣9 at favourable. LHO opens 1♥ (playing weak no-trump and four-card majors), partner overcalls 2♦, RHO cue-bids 3♦, and LHO bids 4♥ accepting the game try.

- a) Do you save in 4♠?
- b) If you don't, partner leads ♦A, and you see:

NS Vul	♠ KQ			
Dealer W	♥ J953			
	♦ Q72			
	♣ AQ54			
<table border="1" style="display: inline-table; border-collapse: collapse;"> <tr><td style="padding: 2px;">N</td></tr> <tr><td style="padding: 2px;">W   E</td></tr> <tr><td style="padding: 2px;">S</td></tr> </table>	N	W   E	S	♠ 9875432
N				
W   E				
S				
	♥ 1076			
	♦ 103			
	♣ 9			

Declarer plays ♦8 at trick one and partner continues with ♦K, declarer following with the jack. If partner leads a third diamond, which card do you play?

- c) In fact, he switches at trick three to ♣3. Declarer gives this some thought, then wins in dummy and leads ♦Q. Which card do you play?

Eleven matches were scheduled for Saturday afternoon. We started well, but got knocked back by a 9-1 loss to Berks & Bucks, the early leaders, in the third round. We scored above average for the rest of the session, and in the last round before dinner faced Lancashire:

EW Vul	♠ AQ6				
Dealer E	♥ AQ8				
	♦ QJ8765				
	♣ 8				
♠ 1053	<table border="1" style="display: inline-table; border-collapse: collapse;"> <tr><td style="padding: 2px;">N</td></tr> <tr><td style="padding: 2px;">W   E</td></tr> <tr><td style="padding: 2px;">S</td></tr> </table>	N	W   E	S	♠ 74
N					
W   E					
S					
♥ 42		♥ K109765			
♦ 103		♦ A92			
♣ AJ10643		♣ Q7			
	♠ KJ982				
	♥ J3				
	♦ K4				
	♣ K952				

W	N	E	S
<b>(Jonathan)</b>		<b>(Paul)</b>	
		2♦ (multi)	2♠
P	4♠	All pass	

W	N	E	S
	<b>(Catherine)</b>		<b>(Julian)</b>
		2♥ (weak)	P
P	3♦	P	3♠
P	4♠	All pass	

The defence starts with two rounds of hearts, West signalling for diamonds. The problem for declarer is that with West having ♦A, East must hold the ♣A, so the defence can take the second round of diamonds and force dummy in clubs, cutting declarer off from the diamond suit. Catherine Draper, for Lancashire, cashed one trump then tried to obfuscate the position by playing clubs herself, running the eight to West's ten. No good, Jonathan saw through the ruse and continued spades. Declarer won in hand and played on diamonds, but by now it was easy for me to read the position, and the contract drifted two off. At the other

table Julian found a better plan, playing on diamonds at trick two. East rose with the ace at once, so Julian unblocked the king, ruffed the heart return high, and claimed 11 tricks when spades and diamonds behaved. East would have done better to duck his ace, but declarer has a counter – cross to a trump and discard his diamond on ♥A, then ruff out the ♦A. West can score a heart or diamond ruff, but that’s only three for the defence.

We won that match 10-0, and, after waiting for Catherine and the rest of an Appeals Committee to reach a just ruling, went for dinner in second place, 3.5 VPs behind Warwickshire, who had benefitted from her judgment.

There were eight matches in the Saturday evening session. We played Hants & IOW in the second round, and the Souths faced this difficult guess in the bidding:

Game All	♠ 76
Dealer W	♥ Q75
	♦ J
	♣ K986532
♠ AK109843	♠ 5
♥ 94	♥ AK10832
♦ 65	♦ K1094
♣ Q7	♣ J10
	♠ QJ2
	♥ J6
	♦ AQ8732
	♣ A4

<b>W</b>	<b>N</b>	<b>E</b>	<b>S</b>
<b>(Paul)</b>		<b>(Jonathan)</b>	
3♠	P	P	3NT
P	P	X	4♦
P	P	X	All pass
<b>W</b>	<b>N</b>	<b>E</b>	<b>S</b>
	<b>(Julian)</b>		<b>(Catherine)</b>
3♠	P	P	3NT
P	P	X	All pass

I’ve stared at the South hand for several minutes, and I still don’t know whether to bid 3NT or pass. On the one hand there are a lot of different hands for partner which will make 3NT, but on the other hand when you’ve guessed wrong to bid it East may well tell you so. (One thing you shouldn’t do is bid 4♦, which is too small a target.) “If in doubt, bid” is a good general rule in competitive sequences, and in practice both Souths tried 3NT. Both Easts doubled – I’m not sure to what extent that suggests a heart lead. Now what should South do? There’s a danger that East will have ♠xx ♥AKQxxx and a few minor suit honours, and the defence will take all thirteen tricks. On the other hand, if, as seems more likely, East has doubled on general values, there’s no reason to think 4♦ will take more tricks than 3NT. For Hants & IOW, Christine Bradley elected to run to 4♦. Jonathan had an easy double, and the defence took an 1100 penalty (declarer could have got out for 800 by ruffing the third heart with a middle diamond).

Catherine chose to take her chances in 3NT. Julian had a long suit to run to, but saw no reason to overrule her. Both very right: with the clubs 2-2 there were nine tricks on a heart lead, with no need to risk the diamond finesse.

The swing of 1850 points all-but guaranteed the aggregate points for the match, which we won 9-1, but there were plenty of difficult hands in the other matches which we were less successful on. After 19 rounds we found ourselves in fourth place, only 1.5 VPs from second, but 15.5 VPs behind the leaders Warwickshire, who had had another good session.

On the short journey from our hotel to the venue on Sunday morning, I ventured that we were too far behind first place to have much of a chance, only to be informed that our absentee



## Point-a-board Teams and Reduced Imps

**Chris Jagger writes:** I welcome the news that on 18-19 January 2014 the EBU is running a point-a-board teams event, a format popular overseas. In point-a-board you simply get a point for each board on which you do better than the opponents. For example if you score 110, and your teammates lose 100, you gain a point. If you gain a game swing you still just gain a point.

So what is wrong with IMPs then?

Take a 12-board match. On boards 1-11 you gently crucify opponents, making an extra overtrick on each board. On board 12 a vulnerable 50% slam goes against you. At IMPs scoring you score 11 IMPs on the first 11 boards, lose 13 IMPs on the last, and lose the match. Few would doubt that you have played better, but one board was worth more than the other 11 put together. At point-a-board scoring (essentially pairs scoring), you have won on 11 boards and lost on only one board. You win comfortably.

This illustrates the fact that IMPs scoring is fundamentally flawed – too many boards are irrelevant, or nearly so. Playing teams with IMP scoring is a good format (teams), but poor scoring system (IMPs). Ordinary pairs has a better scoring system (being like point-a-board, but with points for every pair you beat) but poor format (the flaw is that essentially your teammates are the rest of the field – so whether you win or lose depends on the results at tables that have nothing to do with you – at teams it just depends on the results of your team). Butler or cross-imp pairs have both weaknesses – the format (pairs, so scoring with the rest of the field), and the scoring system (IMPs).

There is in fact one scoring system the EBU uses which is even better than

point-a-board. The Pachabo uses a system that combines point-a-board with a teams element, so that the size of the swing has some importance. It is very complicated, and can easily be improved (leading to some people making easy criticisms of the system without realizing it is still better than ordinary pairs or teams!).

Some other countries use an even better scoring system – RIMPs (Reduced Imps), which combines simplicity with effectiveness. It is like IMPs but with a different scale:

- 1 RIMP for a 20-100 swing
- 2 RIMPs for a 110-300 swing
- 3 RIMPs for a 310+ swing

This format takes account of the fact that most people believe a game swing is worth more than an overtrick, but gives it less importance than IMPs does. In essence, an overtrick or two is worth 1, a partscore swing is worth 2, and a vulnerable game swing is worth 3 (a non-vul game swing is really only a partscore swing anyway).

For example, at RIMPs in a three-board match, if you score an overtrick on boards 1 and 2, and then lose a slam swing on board 3, you would narrowly lose the match (at IMPs it would be a big loss, at point-a-board you would win the match). Alternatively, if you gain a part score swing on boards 1 and 2, and lose a slam swing on board 3, this would be a small win at RIMPs (a small loss at IMPs, a win at point-a-board).

Most people would consider this to be 'fair', and it makes for a much better scoring system – giving all boards more even weight, but still giving some recognition to the size of the swing.

So what are the tactics at RIMPs? You should bid a non-vul game if it is over 50%, a vul game if it is over 40% (which is similar to IMPs), while slam swings get the same amount at vul as not vul (which is sensible as slam swings generally have less to do with vulnerability).

Some people prefer to play the same scoring method but score each board out of 6. So a flat board is 3-3, a 20-100 swing is 4-2, and so on. This has exactly the same result, but can more easily be turned into a percentage score.

## Aunt Agony changes her spots

Dear Auntie,

I had trouble deciding which slam to play in the following hand:

Dealer S	♠ Q7532		
	♥ 2		
	♦ Q87		
	♣ KQ9 <b>3</b>		
♠ J1064		N	♠ K8
♥ 854		W	♥ J1076
♦ K <b>5</b>		E	♦ J943
♣ J8 <b>3</b> 2		S	♣ 1065
	♠ A9		
	♥ AKQ93		
	♦ A10 <b>5</b> 2		
	♣ A7		

W	N	E	S
	(me)		2♣
P	2NT	P	3NT
P	4♥ <sup>A</sup>	P	4♣
P	5♣	P	5♥
P	6♣	P	6♦
P	6NT	All pass	

The 3NT rebid showed 23-24 balanced and I showed my suits, via a transfer. At the time I thought 5♥ agreed clubs, but when he bid 6♦, it looked like he had this sort of hand so I tried for the no-trump slam.

This needed a bit of good fortune. East led ♦3 to the king, and a low club was returned to the ten and ace. I now guessed diamonds correctly, cashing

four rounds. I then played ♠A (Vienna coup) and finessed ♣9. The last round of clubs then squeezed East in the majors. So 6NT made, with only eight top tricks!

What slam would you have chosen, Auntie, and does it make as the cards lie?

Best wishes,

A seeker after truth and thin slams

Dear Nephew,

Well I never. A misfitting 30 count and you ask which slam I would reach. On a bad day I could imagine 3NT going down on some lies and lines. Indeed, the auction 1♥-1♠; 3♦-3NT; Pass is not unreasonable.

If South elects to open 2♣, then North's response isn't so clear.

I usually like responding 2NT on these values, but if you aim subsequently to show your suits, the auction gets uncomfortably high.

I wouldn't bid 2♠ over 2♣ – I try to avoid bidding bad suits on slam auctions. 3♣ has its points, but to my mind a 2♦ response is most practical – you can catch up later. On your sequence, having reached the six-level with no suit agreed, I'd have passed 6♦. Give South ♦J as well, and this is actually a good contract.



Your play in 6NT was fine. However, even after the suicidal club switch at trick 2, if East is inspired enough to allow ♣7 to win, you cannot make 6NT – try it: you can't cash your winners in the right order to squeeze East.

As to which slam has the best chances double dummy, that is a little hard to answer, as you've been a little careless with the spot cards.

Both South and West hold ♦5 in the diagram, while both West and North have ♣3. As we shall see, the missing ♦6 and ♣4 are critical cards.

First of all consider the play in 6♦. With seven tricks in the side suits, declarer hopes to make five trump tricks on a cross ruff.

If North is declarer an initial trump lead scuppers this. West wins ♦K and continues trumps. ♦Q, three hearts and a heart ruff, followed by ♠A and three clubs leads to:

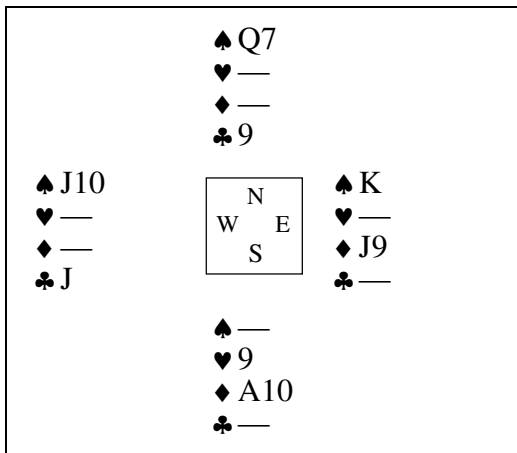

North lacks a winner for the trump coup to work.

However, if SOUTH declares 6♦, things are more promising. Say West leads ♠J. We win with the ace, pitch a spade on the third club and ruff a spade. We then cash three hearts and ruff the fourth heart (it does West no good to ruff high.) We next lead a spade from table in this position:

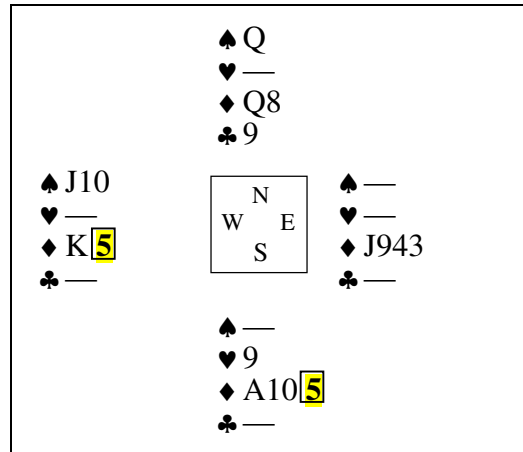

East does best to ruff with ♦J, which we overruff with the ace. We then ruff our heart with the ♦Q, while West discards and East underruffs. It is at this point that it is vital to know who holds ♦6. If West holds it, East covers ♦8 and we lose the last trick, but if declarer holds ♦6, 6♦ by South rolls in. (But not if played by North – maybe you did well not to respond 2♦ after all!)

Does any other slam make? Curiously, 6♠ by South has good chances, despite the ropy trump suit. (If played by North, a diamond lead is fatal.) Suppose West leads a heart against 6♠ by South. South wins, ruffs a heart, and leads a spade, covering West's eight with the nine. West leads another heart, we pitch a diamond, cash ♠A and lead ♥A in this position:

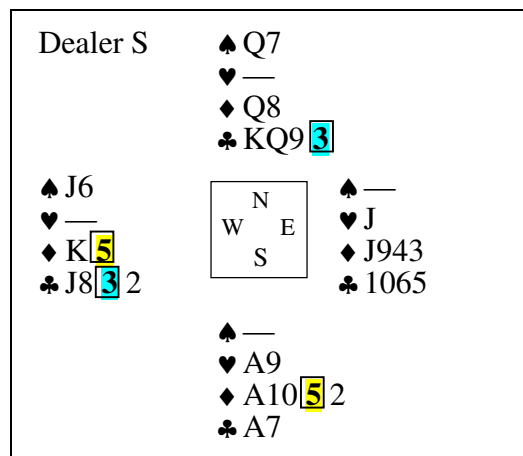

West is now squeezed in three suits including trumps!

If he ruffs, declarer draws trumps and returns to DA and leads the last heart squeezing West in the minors.

If he discards a minor we discard from the other minor, cash three clubs and DA, and then lead our winning heart, making the remainder on a trump coup.

Note that we can't afford to cash hearts or clubs earlier – the trump coup and squeeze is a bit delicate! If we pitch two diamonds on hearts early on, West can discard a diamond when we ruff the fourth heart, and now East has the diamond guard. The squeeze also fails if we cash clubs earlier, due to the lack of a late entry to table.

This suggests the best defence against 6♠ – West should start with a club. When West wins ♠10, he can then lead another club. But the club spots are critical – the ♣2 lead to the ten butchers the suit, just as it did against your 6NT.

We then have no need of a squeeze – after drawing East's trumps, we cash four clubs with the aid of the finesse of ♣9, return to ♦A and run the hearts through West.

But try the effect of leading ♣8 at trick one! This is covered by the nine, ten and ace. After ♥A, heart ruff and a spade to the eight, nine and ten, a second club lead is lethal.

So now your second piece of carelessness with the diagram comes into play. Who holds ♣4?

If West's initial holding is ♣J842 and dummy has ♣KQ93, 6♠ cannot be made on the ♣8 lead. But if West has ♣J832 and North ♣KQ94, then 6♠ by South is cold against any defence!

If dummy holds ♣4, then after ♣8, 9, 10, ace, at trick 2 we run ♣7. If West covers with the jack, this establishes dummy's ♣4 on the fourth round of the suit.

He does best not to cover, which is equivalent to leading ♣2 and East NOT rising with ♣10. We then cash ♥AKQ throwing diamonds, ♦A and ruff a diamond. Now leading a trump isn't good enough, as we haven't established a heart winner in hand (compare the failed trump coup in 6♦ by North).

Instead we cash ♣K and lead ♣Q from table in this position:

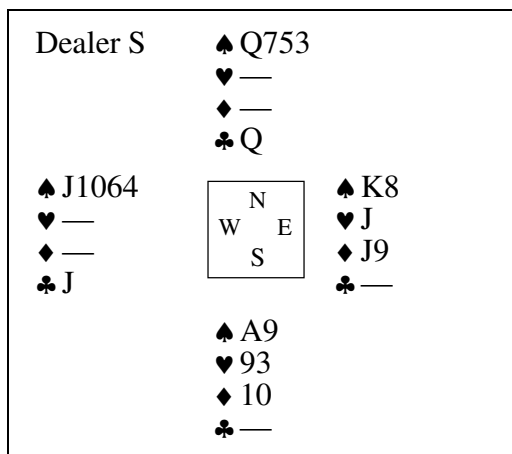

If East does not ruff, we next lead a spade to the nine, and trump-coup West as previously. East does better to ruff high with ♠K, again similarly to the above defence against 6♦. We overruff with the ace and lead a red card. West ruffs with the ten, we overruff with the queen, and lead ♠3 to the eight, nine and ten, endplaying West with ♠64 to lead into our ♠75!

So it looks as though even if dummy holds ♣4, swapping ♠5 and ♠4 means a low club lead will set 6♠.

Well, I do declare. If we hold ♦6 rather than ♦5, then 6♦ makes. If dummy holds ♣4 rather than ♣3 then 6♠ makes, provided he also holds ♠5 and not ♠4. I usually only bid slams when I have lots of high cards – maybe I'm missing out. These silly contracts you seem to reach with lots of low cards can be quite interesting.

Yours, as ever,  
Auntie.

## Fancy a game – but need a partner?

Most of the Cambridge Club's Wednesday duplicate evenings at Chesterton are now hosted. This means that **members and non-members are assured of a game** should they arrive without a partner.

Hosted dates for the rest of 2013 are: 2nd, 9th, 30th October (**not** 16th, 23rd), 6th, 13th, 20th, 27th November, 4th, 11th, 18th December.

The success of hosted evenings will be reviewed by the CBC committee at its next meeting, and they will hopefully

become a permanent feature of the calendar; for hosted dates in 2014 please refer to the CBC website. Any comments on hosting would be welcomed by the CBC committee.

**New faces** are extended a friendly welcome to the club and **pay no visitor premium** – come and be assured of a game!

For directions to CBC's Wednesday venue St Andrews Hall, Chesterton see <http://www.cambridgebridgeclub.org>  
Play commences at 7.30pm.

## Results round-up

### National competitions

Julian Wightwick, Jonathan Mestel, Paul Barden and Cath Jagger retained the Pachabo for Cambs & Hunts.

Cambridge E (Peter Bhagat, John Liebeschuetz, Mike Seaver & Clive Stops) lost the final of the NICKO Plate to West of England C.

Graham Dolan, David Carmichael, Roger Courtney & Robin Cambery won the Essex/Herts One-Day Swiss Teams in July.

In the first weekend of the Brighton Summer Congress, Jon Cooke finished 8th in the Swiss Pairs and stayed on to win the Sunday evening Open Teams, while John Haslegrave & Paul Russell were 3rd in the Friday Midnight Speedball. In the second weekend, Jon Cooke, Paul Barden, Cath Jagger and Jonathan Mestel finished 4th in the A-final of the Teams.

The Cambridge Club comfortably won the Regional Final of the Garden Cities, and then finished fourth in the National Final. It was represented by Julian Wightwick, Victor Milman, Jonathan Mestel, Jon Cooke, Rod Oakford, Mike Seaver, Paul Fegarty, Catherine Curtis, Paul Barden, Cath Jagger and David Kendrick.

In the British Summer Simultaneous Pairs, Colin Campbell and Fred Langford (Balsham) finished 28th in the Monday event, while in the Wednesday event, John Liebeschuetz and Julian Wightwick (Cambridge) finished 22nd.

In the EBU Autumn Simultaneous Pairs, Simon Stokes and Alison Lloyd (North Cambridge) finished 9th in the Monday event, just ahead of Jane Woodhouse and Colin Campbell (Balsham) in 11th. In the Wednesday event, Bob Vajda and Robin Griffiths (Peterborough) finished 13th.

**Eastern Counties League**

The county scored:  
4-16, 0-20 and 3-17 against Norfolk;  
3-17, 9-11 and 10-10 against Beds; and  
5-15, 13-7 and 3-17 against Suffolk.

**County Plate**

Final: KING beat COLLIER

**Cambs & Hunts League 2012/13**

Two divisions had not completed their 2012/13 season at the time of the last newsletter.

**Division 2**

	Team	U1	H3	C4	T1	N2	T4	C3	Total	Ave
1	University 1	+	17	14	20	20	19	13	103	17.17
2	Huntingdon 3	3	+	18	2	15	20	20	78	13.00
3	Cambridge 4	6	2	+	14	17	20	18	77	12.83
4	Thursday 1	0	18	6	+	13	20	19	76	12.67
5	North Cambridge 2	0	5	3	7	+	6	18	39	6.50
6	Thursday 4	1	0	0	0	14	+	15	30	6.00
7	Cambridge 3	7	0	2	1	2	5	+	17	2.83

Congratulations to University 1, who won their last match 20-0, pushing their opponents Thursday 1 from second down to fourth.

**Division 3**

	Team	P4	E2	S1	U2	E3	P5	Total	Ave
1	Peterborough 4	+	11	4	14	20	19	68	13.60
2	Ely 2	9	+	20	0	17	19	65	13.00
3	Saffron Walden 1	16	0	+	10	12	20	58	11.60
4	University 2	0	20	10	+	10	14	54	10.80
5	Ely 3	0	3	8	10	+	8	29	5.80
6	Peterborough 5	1	1	0	6	12	+	20	4.00

Congratulations to Peterborough 4 on winning Division Three.

## Around the Clubs

**Cambridge**

The Abdelmoneim Trophy for the summer pairs ladder was won again by Nadia Stelmashenko & Victor Milman, narrowly beating Jon Cooke and Paul Barden.

The Autumn Equinox Handicap event for the Zakrzewska Plate was won by Ivo Miller & David Collier.

Alex Green is now running lessons for complete beginners at Trumpington Village Hall on Tuesday evenings.

Hosted evenings are continuing on Wednesdays through October, November and December (except 16th and 23rd October) – see page 11 for more details. Members and non-members are welcome to come without a partner and are assured of a game.

### Huntingdon

The Stuart Morton Handicapped Teams was won by Gill Davies, Marilyn Howells, Jaqui Racey & Sheila Povall.

The Alan Knott Individual Trophy was won by Gary Kendall.

### North Cambridge

The monthly Prize Pairs have been won by Tanawan Watts & Roger Salmon (May), Verity Joubert & Fred Allen (June), Eric Campbell & Ian Aldridge (July), TED Shaw & Graham Clarke (August) and Susan Mealing & Simon Stokes (September).

### Peterborough

As Peterborough Council has changed the plans for the club's future premises, it will continue to meet at the existing premises for the foreseeable future.

The Men's Pairs was won by Tony Hough & Tim Durdin, while the Ladies Pairs was won by Marion King & Marian Freeman.

### Thursday

Fred Allen won the Individual Ladder. Joanne Caldwell & Kevin Smith won the Teams Ladder

TED Shaw & Vera Donert won the Unusual Partner Pairs.

The Handicap Teams event for the Fry Trophy was won by Rosanne Mattick, Fred Allen, Sally Dempster & Betty Knight.

The Orchard Pairs was won by Fred Allen & Roger Salmon.

## CHARITY BRIDGE DAY WITH ANDREW ROBSON

10-3.30, Thursday 27th March 2014 at Fulbourn Centre, CB21 5BS

Andrew is widely regarded as one of the finest Bridge player/teacher/writers in the world today. He will provide expert tuition and advice throughout the day.

A raffle will be held and all proceeds of the raffle and the Charity Day will go the Macmillan Cancer Support.

10.00 – 10.30	Arrival – coffee and biscuits
10.30 – 12.30	Tuition play session led by Andrew
12.30 – 13.30	Lunch
13.30 – 15.30	Tuition play session led by Andrew

Tickets are available from Monday 14th October £35.00 per person, including coffee, lunch, and tuition from Andrew.

Contact: Marlene Gillson, mgilson155@btinternet.com, 01223 841155.

## Cambs & Hunts CBA County Calendar 2013-14

*Except for the Novice Pairs all competitors must be members of the EBU (either directly or as a member of a club). Full details of events and entry forms are available from clubs, the event organiser, or on [www.cambsbridge.org.uk](http://www.cambsbridge.org.uk). All events start at 1pm except where otherwise stated.*

***Please note several entry fees have been reduced!***

- |  |  |
|--|--|
| Monday 14th<br>October 2013                        | Closing date for entries to the <b>County Teams Knockout. NOW FREE!</b> The major green-pointed teams-of-four championship with matches played privately. The winners represent the County in the Pachabo. There is also a Plate event for first round losers, so no excuse for not entering this one! (Organised by Chris Jagger. <a href="mailto:chjagger@deloitte.co.uk">chjagger@deloitte.co.uk</a> , 14 St Barnabas Court, CB1 2BZ. Tel 01223 321910) |
| Sunday 27th<br>October 2013<br>Trumpington         | <b>Cambs and Hunts Open Swiss Teams</b><br>The County's prestige teams-of-four competition.<br>Also featuring Blue Points at no extra cost!<br>(Organised by David Man <a href="mailto:davidman22@talktalk.net">davidman22@talktalk.net</a> Tel: 01223 660312)   |
| Sunday 23rd<br>February 2014<br>Trumpington        | <b>County Individual Final</b><br>This is what bridge is all about! All partner all and only a simple system is permitted. Qualifying heats to be held in clubs by 16 December.<br>Pester your club to hold a heat. <b>Entry now only £1 per person.</b><br>Clubs: to register your heats please email Paul Russell: <a href="mailto:p.a.russell@dpmms.cam.ac.uk">p.a.russell@dpmms.cam.ac.uk</a>  |
| 8th-9th<br>March 2014                              | <b>East Anglian Bridge Weekend</b><br>Consists of 1 day Swiss Teams and 1 day Swiss Pairs, held for the first time last year.<br>(Queries can be addressed to Paul Bond at <a href="mailto:EABW@systems.co.uk">EABW@systems.co.uk</a> )  |
| Saturday 22nd<br>March 2014<br>Trumpington<br>10am | <b>Novice Pairs Tournament</b><br>For inexperienced players and players new to tournament bridge.<br>(Organised by Gladys Gittins email: <a href="mailto:gladys.g40@ntlworld.com">gladys.g40@ntlworld.com</a> )  |
| Sunday 23rd<br>March 2014<br>Trumpington           | <b>County Pairs Final</b><br>The green-pointed final of the County's premier pairs event. The leading three pairs represent the county in the Corwen. Qualifying heats held in clubs by 31 January.<br><b>Entry now only £1 per person.</b><br>Clubs to register your heats please email Peter Grice <a href="mailto:pg10003@cam.ac.uk">pg10003@cam.ac.uk</a> )  |
| Saturday 5th<br>April 2014<br>Peterborough         | <b>Garden Cities Qualifier</b><br>One Day club teams of eight (clubs may enter more than one team). The winning club represents the County in the Regional Final. £48 per team.<br>(Organiser: Trevor King: <a href="mailto:Trevor@alpinebridge.co.uk">Trevor@alpinebridge.co.uk</a> Tel: 01733 572457)  |
| Sunday 27th<br>April 2014                          | <b>County Swiss Pairs</b><br>A popular pairs competition in Swiss format with six 8 board matches.<br>(This event will only run if we can find an organizer for it.)   |

Eastern Counties League dates are published separately, by Chris Larlham, [CLar365164@aol.com](mailto:CLar365164@aol.com).

# Cambs & Hunts Open Swiss Teams

*Competition for the Margaret Hyde Trophy*

## Blue Pointed

---

Sunday 27th October 2013 starting at 1.00 pm.

Trumpington Village Hall, CB2 9HZ

Prizes awarded to the Top 3 Teams and Ascenders Prize

Two sessions of play. Includes plated afternoon tea\*.

Licensed by the EBU

***Entry fee £56.00 per team***

Tournament Director: Peter Grice

Venue limits entry to maximum of 16 teams. Early entry advised.

---

**Entry Form** (please detach)

**Cambs & Hunts Open Swiss Teams**

EBU Numbers

Team Captain: \_\_\_\_\_

Player 2: \_\_\_\_\_

Player 3: \_\_\_\_\_

Player 4: \_\_\_\_\_

Captain's preferred contact details:

Telephone No: \_\_\_\_\_ Email: \_\_\_\_\_

Please send cheque for £56 (payable to "Cambs & Hunts C.B.A.") to:

David Man, 31 Radegund Road, Cambridge. CB1 3RH

Enquiries to: [davidman22@talktalk.net](mailto:davidman22@talktalk.net) and 01223-660312

\*Please advise of any dietary requirements\*